



# Taking flooring technology one step forward

Productivity  
Performance  
Strength



# NRT Pre-attached underlayment with kraft paper carrier

Higher line productivity and better technical performance.



This option is now available for the references NRT 45, NRT 49 and NRT 62.

## Main benefits



### Increased line productivity

The placement of a paper carrier in the NRT pre-attached underlayment's components makes it possible to optimize the production output. The manufacturing process is faster, requires short downtime periods, with less loss of product in the line. In addition to increasing production capacity, this combination adapts more easily to demanding lines in terms of conformation (with angles, for example).



### Better technical performance

The addition of a paper carrier not only speeds up the manufacturing process, it also makes it easier. The product's tensile strength increases\*, facilitating its integration into the system. The paper carrier also makes the surface of the pre-attached underlayment more homogeneous, ensuring a better performance in adhering to other layers of the floor.



### Sustainable by nature

The NRT Pre-attached underlayment with kraft paper solution is a sustainable choice. Cork is a 100% natural, reusable and recyclable raw material, offering numerous benefits for the planet. This component is combined with a kraft paper carrier produced with materials from forests certified by the Forest Stewardship Council® (FSC).



### Innovation at the service of the industry

Amorim Cork Composites continuously invests in research and technology to offer the market innovative and efficient solutions. The new kraft paper carrier for NRT pre-attached underlayment is the result of this commitment. We produce in our factories using sophisticated hotmelt laminating equipment. This system makes it possible to add different layers to cork, enhancing its properties and creating solutions that respond to manufacturers' needs and requirements.

\* For example, the addition of a laminated kraft paper to the NRT 45 with a 0,9 mm thickness will increase 1Mpa of tensile strength.



NRT (Noise Reduction Technology) pre-attached underlayment solutions can now be produced with a kraft paper carrier incorporated through a hotmelt lamination.

Combining the benefits of paper with the advantages of cork, the pre-attached underlayment component, as part of a flooring system, offers a solution that optimizes the manufacturing process and improves the performance of the final product.

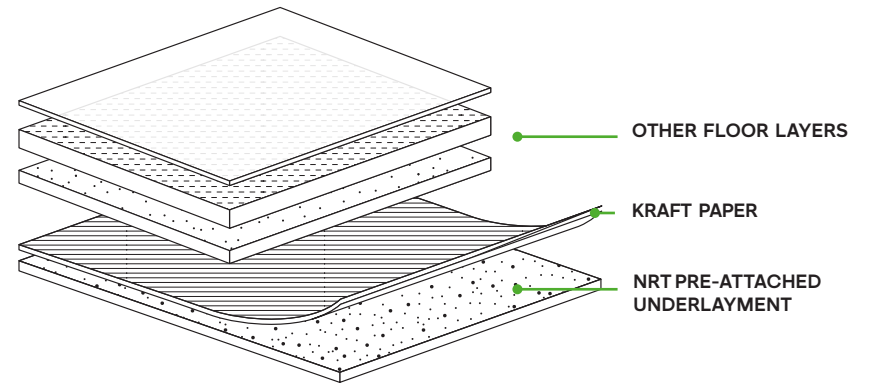

NRT 45 pre-attached underlayment with kraft paper carrier laminated with 0,9 mm thickness. In this case, the tensile strength will increase 1Mpa.



---

**Amorim Cork Composites**

Rua Comendador Américo Ferreira Amorim, 260  
4535-186 Mozelos, Santa Maria da Feira, Portugal  
T. +351 22 747 5300 F. +351 22 747 5301 E. [info.acc@amorim.com](mailto:info.acc@amorim.com)

---

**Amorim Cork Composites USA**

26112 110th Street  
Trevor, WI 53179, USA  
T. +1 262 862 2311 F. +1 262 862 2500 E. [info.acc.usa@amorim.com](mailto:info.acc.usa@amorim.com)

---

[www.amorimcorkcomposites.com](http://www.amorimcorkcomposites.com)

The data provided in this brochure refers to typical figures. This information is not intended to be used as a purchasing specification and does not imply suitability for use in any specific application. Failure to select the proper product may result in either product damage or personal injury. Please contact Amorim Cork Composites regarding recommendations for specific applications. Amorim Cork Composites expressly disclaims all warranties, including any implied warranties of merchantability or of fitness for any particular purpose. Amorim Cork Composites shall not be liable for any indirect, special, incidental, consequential or punitive damages as a result of using the information listed in this brochure, any of its material specification sheets, its products or any future use or re-use of them by any person or entity. For contractual purposes, please request our Product Specifications Sheet (PDA).

---

# AMORIM CORK COMPOSITES

AOC.942 | FEB.2021 | EN